

## BOX SERIES

# MULTIHEAD WEIGHER

## BOX 140-10P

### Applications:

- Potatoes
- Onions
- Peppers
- Citrics
- Kiwis
- Avocado
- Nuts
- Similar Washed Fruits.

*Progress and dosage of the product through specially balanced vibrators avoiding probes and friction in the product.*

*System composed of double hoppers with hopper preload and retención. It allows to increase the output frequency. 10 Hoppers driven by pneumatic cylinders with smooth or lapping surface depending on the product.*

*You can feed: to two TOP or similar packaging machines simultaneously with FLAP & DOUBLE BELT.*

*All materials for APPROVED FOR FOOD PURPOSE easy to clean and preserve. Simple access for cleaning and service.  
It incorporates an intelligent weighing system designed to find the perfect combination or closest to the programmed weight with a margin of error of less than one gram.*

*Quick installation, assembly and dismounting*

**For fruits from 40 to 130mm in diameter**

**Weight range of 250 grs. to 5 kg.**

**Optimal treatment of the product**

**Removable cuvette housing.**

**Accuracy of weighing + - 0.2%**

**Speed. 25 to 30 weights / minute**

**Reject bucket load "out range"**

**Intuitive user interface**

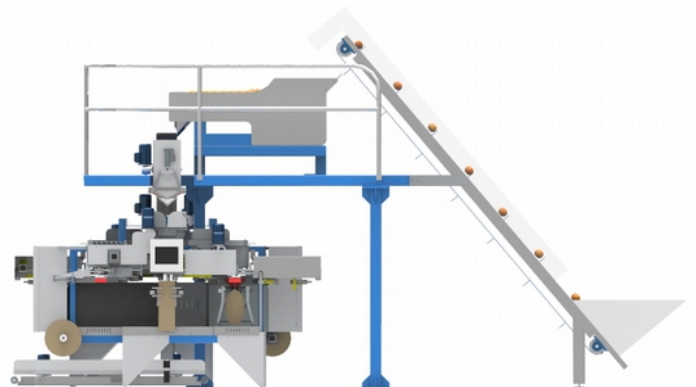

**BOX SERIES**

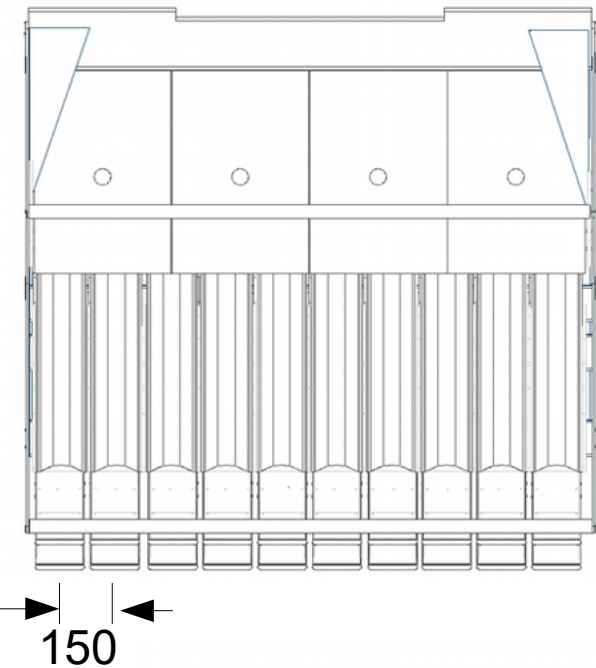
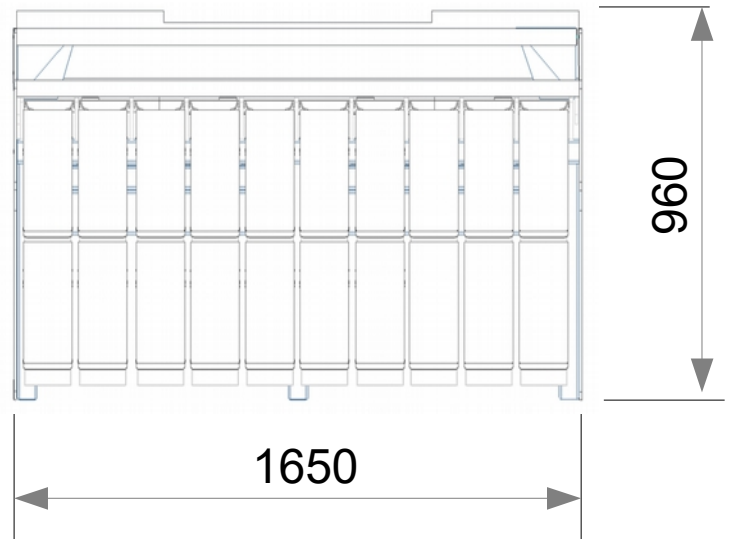
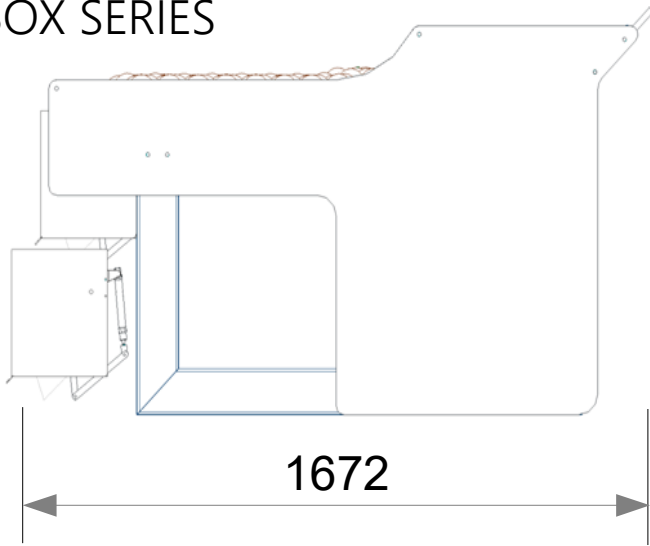

**Main Characteristics**

Tension: 230-415 V. AC  
 Frequency: 50 to 60 Hz.  
 Power: 2 Kw.

Air pressure: 6 Bar  
 Consumption: 100 liters / min

Materials:  
 APPROVED FOR FOOD PURPOSE  
 E.U.

Protection class: IP54  
 Ambient temperature: 5°C -40°C

Total Weight: 700 Kg  
 Dimensions.  
 Distance between channels. 150 mm  
 Vibrating platforms: 10 + 4  
 Separators channels: 11 Teflon

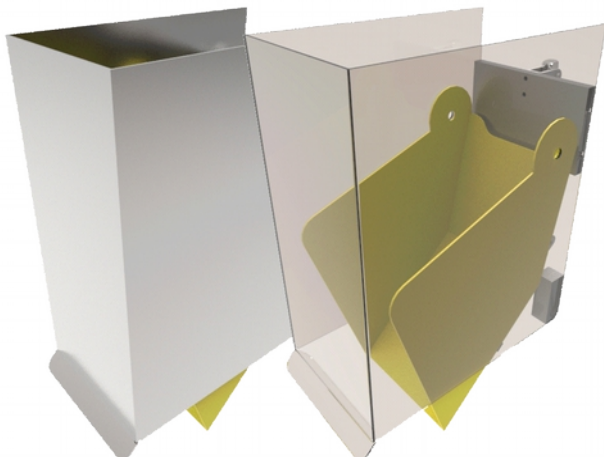

Cube: 142 x 315 x 250

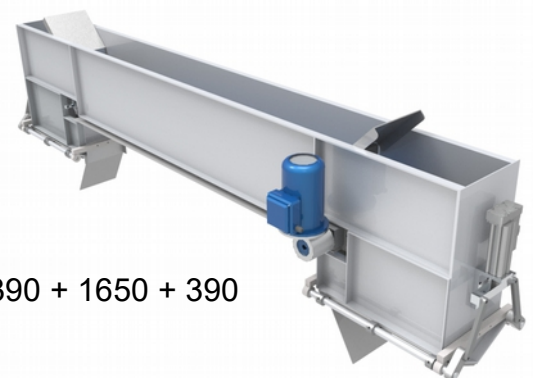

Belt: 390 + 1650 + 390

By: